

Gear Head Operator



GHO MODEL SHOWN



GHO

Industrial Duty Gear Head Operators are engineered for high lift & vertical lift sectional doors, rolling doors, and rolling grilles.

FEATURES

- 1/2 HP, 3/4 HP, 1 HP, 1 1/2 HP and 2 HP - 115V/230V-1 Phase Motor
 - 208/230/460/575V-3 Phase Motor
- 3 Button station (NEMA 1)
- 1650 RPM, high starting torque motor with overload protection
- LX 100 BOARD Standard Features (See Accessories cut sheet for more details)
 - B2 Mode, C2 Mode, D1 Mode, E2 Mode, T Mode, TS Mode
- On board, Open, Close, & Stop for ease of setting limits
- Photo-eyes included
- Pre-wired to accept sensing devices
- 24 Volt accessory power
- On board (372 MHz) receiver capable of programming up to 20 transmitters
- External receiver connection
- NEMA 1 Electrical enclosure
- Primary Drive: 44:1
- 37.5 RPM output shaft speed
- Door speed determined by the door system installed
- Standard sprockets:
 - Sectional: 50B12 x 1" bore to 50B36 x 1" bore or 50B36 x 1 1/4" bore
 - Steel Rolling (Small to medium door): 50B12 x 1" bore to 50B36 x 1 1/4" bore
 - Steel Rolling (Large door): 50B12 x 1" bore to 50B48 x 1 1/4" bore or 50B48 x 1 1/2" bore
- Warranty
 - 2 years on parts and motor

GHO Series

	STANDARD	
	HOIST	SOLENOID
		BRAKE
GHO	X	X



SHOP DIAGRAMS

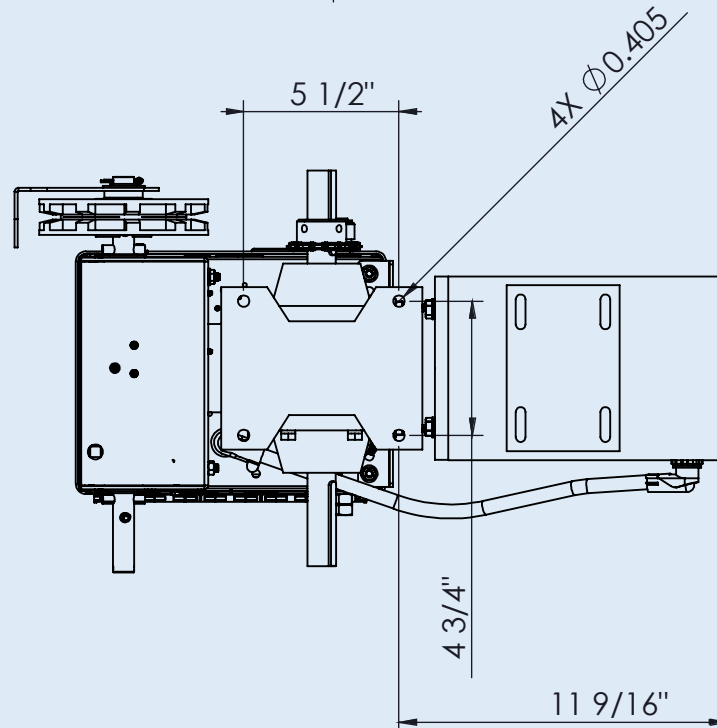
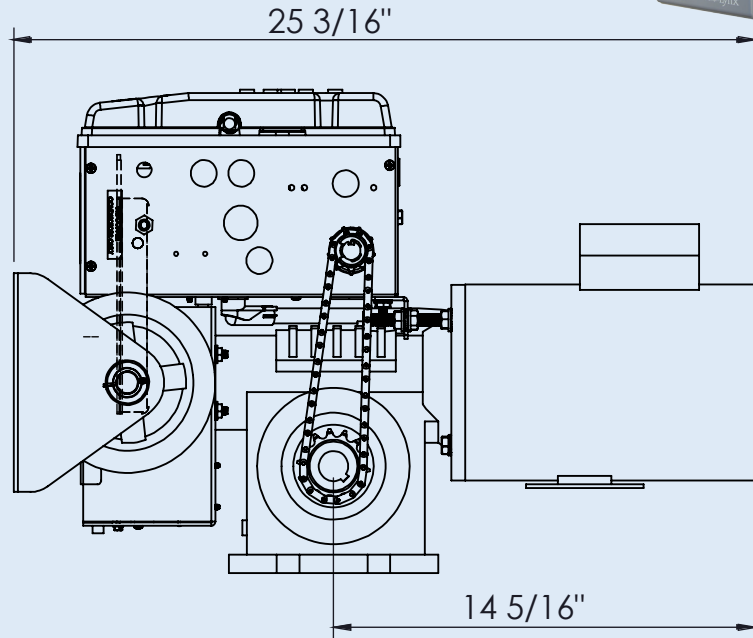
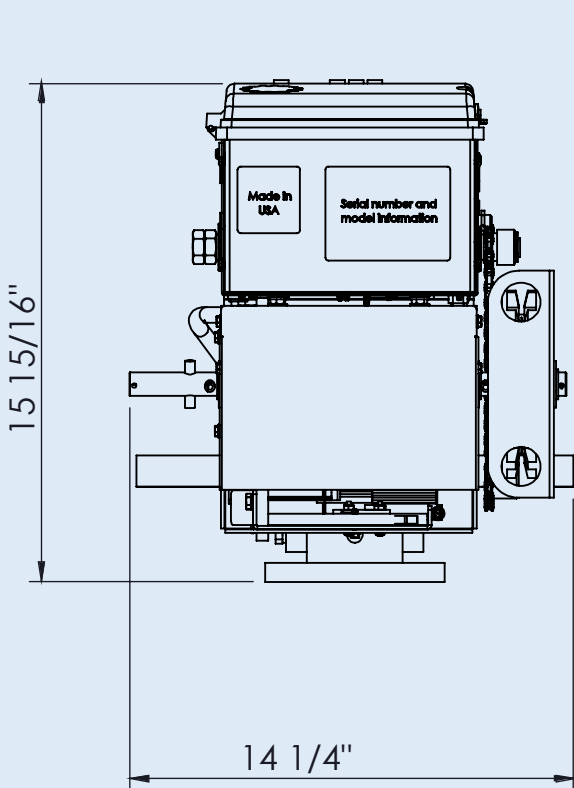

Intertek



PROUDLY ASSEMBLED IN NORTH AMERICA

READY TO ORDER?

Please have the following information available:

- Height and width of the door
- Shaft size
- HP/Voltage
- Rolling or sectional door
- Number of transmitters needed
- Antenna needed

800-233-3599
ARIZONA

101 N. 57th Ave.
Phoenix, AZ
85043

800-234-5969
NEW JERSEY

613 Industrial Rd.
Carlstadt, NJ
07072

800-338-5399
OHIO

111 Weires Dr.
Archbold, OH
43502

888-589-5969
QUEBEC

175 Upper Eddison Ave.
St. Lambert, QC
J4R 2R3

888-839-5969
ONTARIO

6311 Vipond Dr.
Mississauga, ON
L5T 1T7